

SNAP Analog Output Module

Features

- Resolution = 0.004% of nominal range
- Rugged packaging
- Convenient pluggable wiring
- Powered by a single 5-volt supply
- Factory calibrated; no user adjustment necessary
- Out-of-range indication
- Operating temperature 0 °C to 70 °C
- Accepts up to 14 AWG wire

Description

SNAP I/O analog output modules are part of Opto 22's SNAP PAC System. They mount on SNAP PAC racks along with other I/O modules and a SNAP PAC brain or R-series controller, either a standard wired or a Wired+Wireless™ model.

These software-configurable output modules handle a wide variety of signal levels. Most provide dual-channel packaging. All SNAP analog modules are factory calibrated. Part numbers ending in -FM are Factory Mutual approved.

SNAP analog output modules have an on-board microprocessor to provide module-level intelligence, which makes them an ideal choice for Original Equipment Manufacturers (OEMs). For additional information about the stand-alone operation of SNAP analog modules, please refer to the *SNAP I/O Module Integration Guide* (Opto 22 form #876).

SNAP racks use a retention rail locking system that holds modules securely to the rack. Normally, a hold-down screw is not required. However, for applications that require additional module security, each module has provisions for two 4-40 by ½-inch standard machine screws to hold each module in position on the SNAP rack.

For specifications and wiring diagrams, see the module descriptions starting on [page 2](#). Dimensional drawings begin on [page 10](#).

Notes for legacy hardware: SNAP analog output modules can also be used with legacy SNAP Simple, SNAP Ethernet, and SNAP Ultimate brains and with serial SNAP brains such as the B3000. These modules can be mounted on SNAP B-series or M-series racks.

Isolation

All SNAP analog output modules are transformer isolated as well as optically isolated from all other modules and from the I/O processor (SNAP PAC brain or on-the-rack controller). On most dual-channel modules, the two channels are *not* isolated from each other. The



SNAP Analog Output Modules

exceptions are the SNAP-AOA-23-iSRC and the SNAP-AOD-29, which have two isolated channels.

Transformer isolation prevents ground loop currents from flowing between field devices and causing noise that produces erroneous readings. Ground loop currents are caused when two grounded field devices share a connection, and the ground potential at each device is different.

Optical isolation provides 4,000 volts of transient (4,000 V for 1 ms) protection for sensitive control electronics from industrial field signals.

IMPORTANT: Since most SNAP dual-channel analog output modules provide two single-ended output channels with a common reference, these dual channels are transformer and optically isolated from other modules, but not from each other. The exceptions are the SNAP-AOA-23-iSRC and the SNAP-AOD-29, which have channel-to-channel isolation.

Part Numbers

Part	Description	See
SNAP-AOA-3	Single-channel current output, 4–20mA	pg 2
SNAP-AOV-5	Single-channel analog voltage output, 0 to 10 VDC	pg 3
SNAP-AOA-23	Dual-channel analog output, current loop, 4–20mA	pg 4
SNAP-AOA-23-iSRC SNAP-AOA-23-iSRC-FM*	Isolated dual-channel analog output, current loop, 4–20 mA, with loop sourcing	pg 5
SNAP-AOV-25	Dual-channel analog voltage output, 0 to 10 VDC	pg 6
SNAP-AOV-27	Dual-channel analog voltage output, -10 to +10 VDC	pg 7
SNAP-AOA-28	Dual-channel analog output, current loop, 0–20 mA	pg 8
SNAP-AOD-29	Dual-channel analog time-proportional digital output, 5 to 60 VDC	pg 9

* Factory Mutual approved

Single-Channel Current Output 4–20 mA

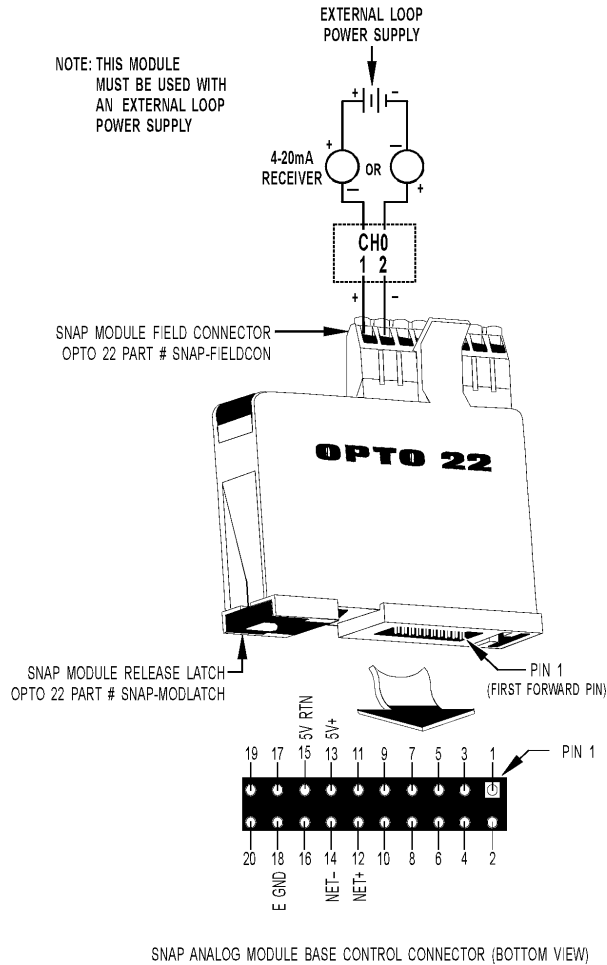

IMPORTANT: The mounting rack connector has 24 pins; the module connector has 20 pins. The extra pins on the mounting rack connector prevent misalignment of the module during installation.

SNAP Analog Output Modules

Part Number	Description
SNAP-AOA-3	Single-channel analog output 4–20 mA

Description

The SNAP-AOA-3 module provides a single channel of transformer and optically-isolated digital to analog conversion. The module has a true differential (floating) output that eliminates ground loops and has a nominal output range of 4 mA to 20 mA.

Specifications:

Input	12-bit serial data
Output	4 to 20 mA (floating)
Span	16 mA
Resolution	3.9 microamps
Response Time (% of span/delta I/ delta time)	99.9%/15.98 mA/3 mS
DC Common Mode Rejection	>-120 dB
AC Common Mode Rejection	>-120 dB @ 60 Hz
Maximum Operating Common Mode Voltage	250 V
Common Mode Resistance	>1000 M W
Accuracy	0.1% of span
Gain Temperature Coefficient	50 PPM/ °C
Offset Temperature Coefficient	20 PPM/ °C
Module Power Requirements	5 Volts DC (±0.15) @ 140 mA
Loop Power Requirements	10 Volts DC (min) to 32 Volts DC (max)
Max. Loop Resistance (Ohms) @ Loop Supply	250 350 950 1350 10V 12V 24V 32V
Max. Loop Resistance formula	$\frac{(\text{Loop Voltage} - 5)}{0.02}$
Ambient Temperature: Operating Storage	0 °C to 70 °C -25 °C to 85 °C

SNAP Analog Output Modules

Single-Channel Voltage Output 0–10 VDC

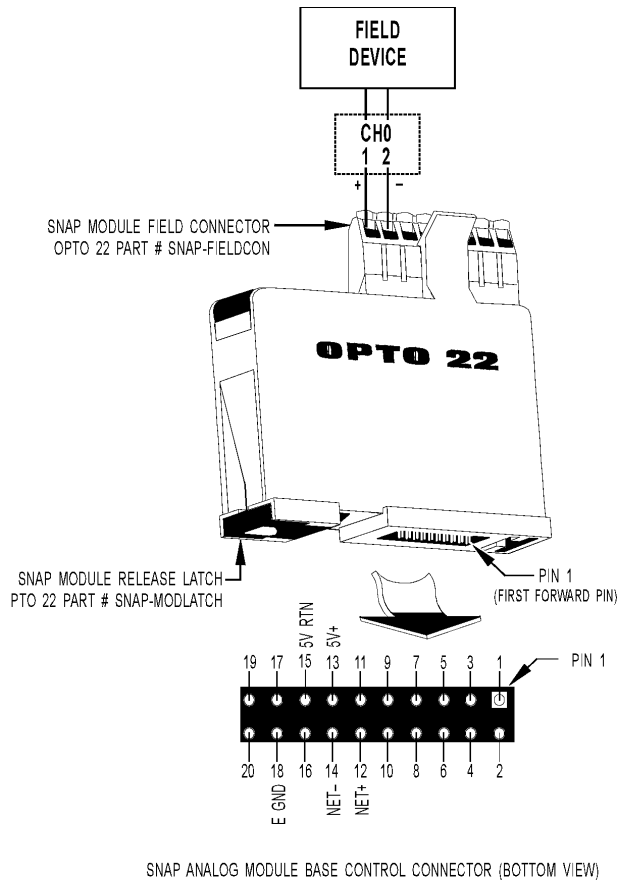

IMPORTANT: The mounting rack connector has 24 pins; the module connector has 20 pins. The extra pins on the mounting rack connector prevent misalignment of the module during installation.

Part Number	Description
SNAP-AOV-5	Single-channel analog output voltage 0 to 10 VDC

Description

The SNAP-AOV-5 module provides a single channel of transformer and optically-isolated digital to analog conversion. The module has a true differential (floating) output that eliminates ground loops and has a nominal output range of 0 VDC to +10 VDC.

Specifications:

Input	12-bit serial data
Output	0 to +10 Volts DC (floating)
Span	10 Volt span
Resolution	2.44 mV
Response Time (% of span/delta V/delta time)	99.9%/19.98 V/3 mS
DC Common Mode Rejection	>-120 dB
AC Common Mode Rejection	>-120 dB @ 60 Hz
Maximum Operating Common Mode Voltage	250 V
Common Mode Resistance	>1000 Megohms
Load Current	10 mA (floating)
Short Circuit Current Continuous	125 mA (typical)
Accuracy	0.1% of span
Gain Temperature Coefficient	50 PPM/°C
Offset Temperature Coefficient	20 PPM/°C
Power Requirements	5 Volts DC @ 150 mA
Ambient Temperature: Operating Storage	0 °C to 70 °C -25 °C to 85 °C

Dual-Channel Current Output 4–20 mA

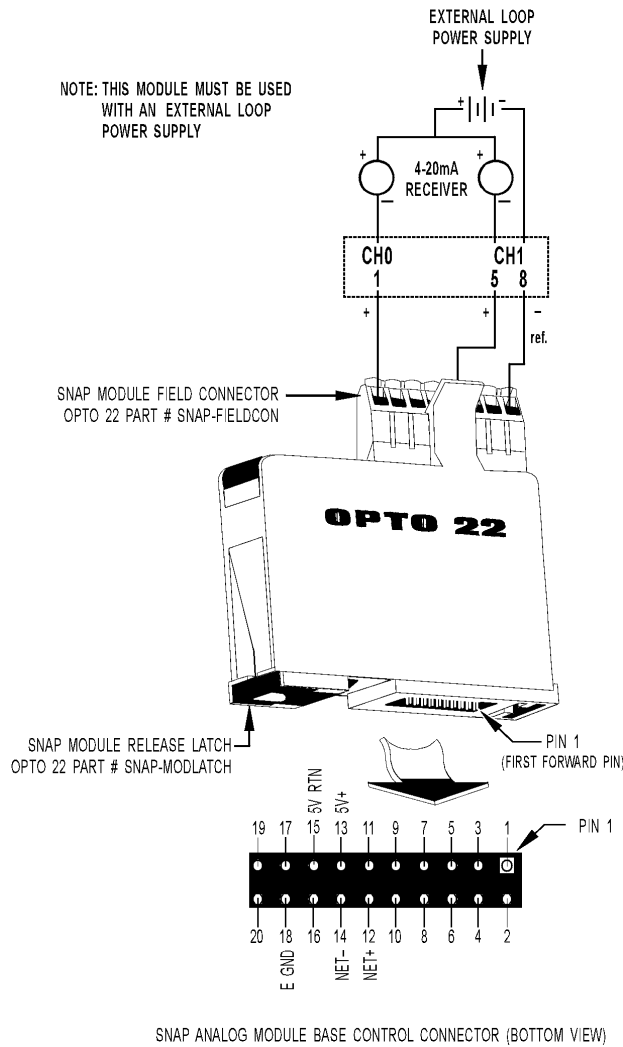

IMPORTANT: The mounting rack connector has 24 pins; the module connector has 20 pins. The extra pins on the mounting rack connector prevent misalignment of the module during installation.

SNAP Analog Output Modules

Part Number	Description
SNAP-AOA-23	Dual-channel analog output current loop 4–20 mA

Description

The SNAP-AOA-23 module provides a nominal output range of 4 mA to 20 mA. An external loop power source is required for the current loops.

NOTE: Both channels share common reference terminals. Common reference terminals are 3, 4, 7, and 8.

Specifications:

Input	12-bit serial data (each channel)
Outputs	4 to 20 mA (each channel)
Span	16 mA
Resolution	3.9 microamps
Response Time (% of span/delta I / delta time)	99.9%/15.98 mA/3 mS
DC Common Mode Rejection	>-120 dB
AC Common Mode Rejection	>-120 dB @ 60 Hz
Maximum Operating Common Mode Voltage	250 V
Common Mode Resistance	>1000 Megohms
Accuracy	0.1% of Span
Gain Temperature Coefficient	50 PPM/°C
Offset Temperature Coefficient	20 PPM/°C
Module Power Requirements	5 Volts DC (±0.15) @ 150 mA
Loop Power Requirements	8 VDC (min) to 32 Volts DC (max)
Max. Loop Resistance (Ohms) @ Loop Supply	250 450 650 1050 1450 8V 12V 15V 24V 32V
Max. Loop Resistance formula	$\frac{(\text{Loop Voltage} - 3)}{0.02}$
Ambient Temperature: Operating Storage	0 °C to 70 °C -25 °C to 85 °C

SNAP Analog Output Modules

Isolated Dual-Channel Current Output 4–20 mA

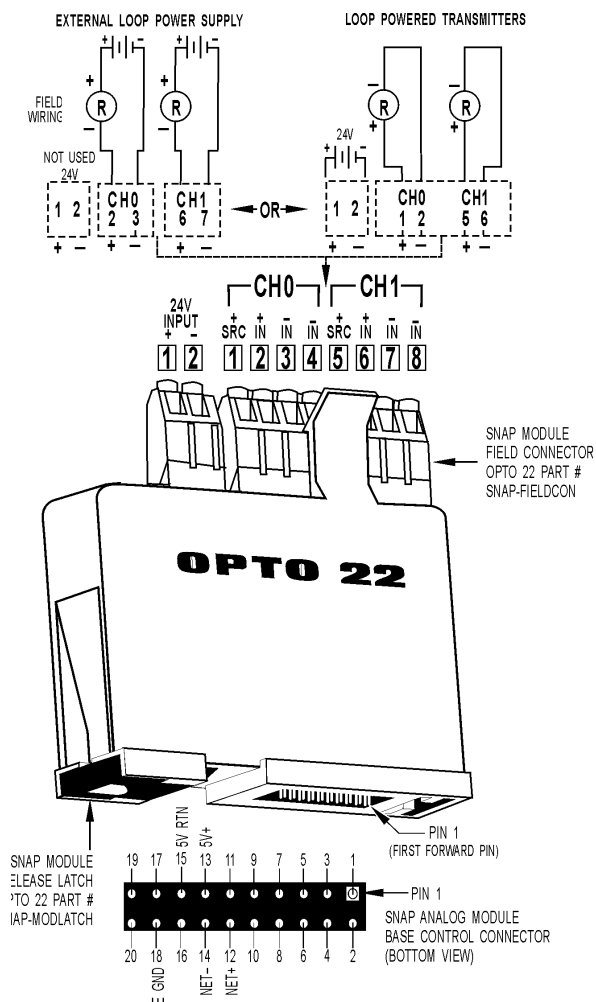

IMPORTANT: The mounting rack connector has 24 pins; the module connector has 20 pins. The extra pins on the mounting rack connector prevent misalignment of the module during installation.

Description

The SNAP-AOA-23-iSRC and SNAP-AOA-23-iSRC-FM modules provide a nominal output range of 4 mA to 20 mA. These modules include built-in loop sourcing capability.

The SNAP-AOA-23-iSRC-FM is Factory Mutual approved.

Part Number	Description
SNAP-AOA-23-iSRC	Isolated dual-channel analog 4–20 mA output with loop sourcing
SNAP-AOA-23-iSRC-FM	

With the connection of a single 24 V power supply, these modules source two 24 V loops. The loop sources are internally connected to the individual outputs. The two channels and their loop sources are isolated from each other; they do not share any field connection. In addition, each loop source is current limited so that an external fault on one loop will not affect the other.

Specifications:

Input	12-bit serial data (each channel)
Outputs	4 to 20 mA (each channel)
Span	16 mA
Resolution	3.9 microamps
Response Time (% of span/delta I / delta time)	99.9%/15.98 mA/3 mS
DC Common Mode Rejection	>-120 dB
AC Common Mode Rejection	>-120 dB @ 60 Hz
Maximum Operating Common Mode Voltage	250 V
Common Mode Resistance	>1000 Megohms
Accuracy	0.1% of Span
Gain Temperature Coefficient	50 PPM/°C
Offset Temperature Coefficient	20 PPM/°C
Max. Loop Resistance @ Loop Supply	950 Ohms
Ambient Temperature: Operating Storage	0 °C to 70 °C -25 °C to 85 °C
Isolation: Optical	4000 V
Isolation: Transformer	1500 V
Isolation: Channel to Channel	250 V continuous (1500 V transient)
Power Requirements	5 Volts DC (±0.15) @ 200 mA
Power Requirements - Loop Power (Input)	From separate field connector; 24 VDC nominal (70 mA max) @ 24 V input, both loops @ 20 mA), 30 VDC maximum
Loop Power (Output)	24 VDC (±1.5 V) @ 20 mA Open loop: 30 V maximum Shorted loop: 24 mA nominal

Dual-Channel Voltage Output 0–10 VDC

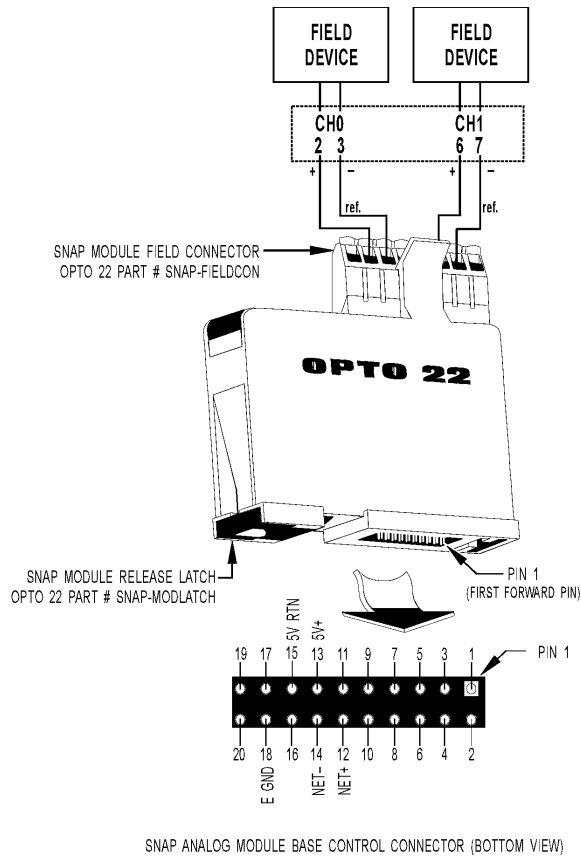

IMPORTANT: The mounting rack connector has 24 pins; the module connector has 20 pins. The extra pins on the mounting rack connector prevent misalignment of the module during installation.

SNAP Analog Output Modules

Part Number	Description
SNAP-AOV-25	Dual-channel analog output voltage 0 to 10 VDC

Description

The SNAP-AOV-25 module provides a nominal output range of 0 to +10 volts. Each channel can supply +5 mA of load current.

NOTE: Both channels share a common reference terminal.

Specifications:

Input	12-bit serial data (each channel)
Outputs	0 to +10 Volts DC
Span	10 Volts
Resolution	2.44 mV
Response Time (% of span/delta V/delta time)	99.9%/19.98 V/3 mS
DC Common Mode Rejection	>-120 dB
AC Common Mode Rejection	>-120 dB @ 60 Hz
Maximum Operating Common Mode Voltage	250 V
Common Mode Resistance	>1,000 Megohms
Load Current (nominal)	5 mA (each channel)
Short Circuit Output Current Continuous	40 mA per channel
Accuracy	0.1% of Span
Gain Temperature Coefficient	50 PPM/°C
Offset Temperature Coefficient	20 PPM/°C
Power Requirements	5 Volts DC (±0.15) @ 150 mA
Ambient Temperature: Operating Storage	0 °C to 70 °C -25 °C to 85 °C

SNAP Analog Output Modules

Dual-Channel Voltage Output -10 to +10 VDC

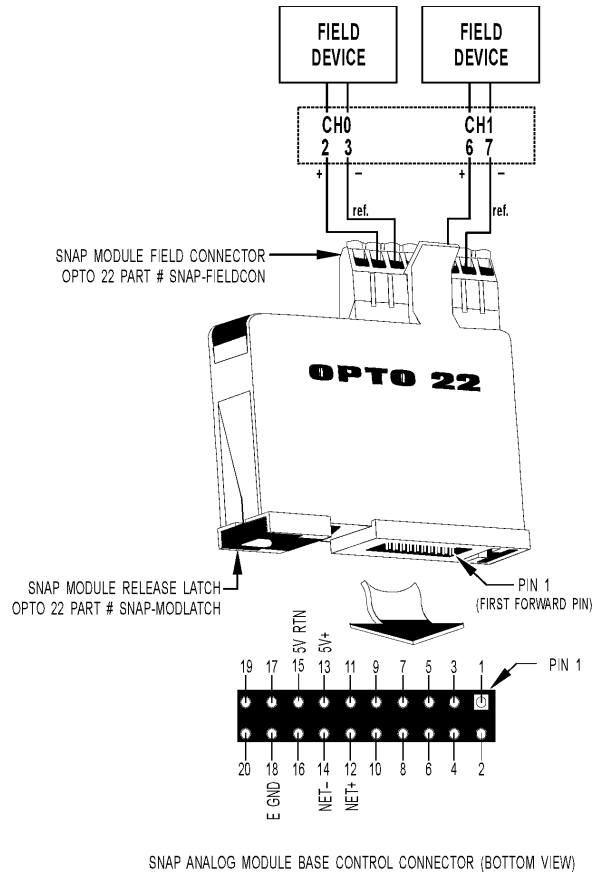

IMPORTANT: The mounting rack connector has 24 pins; the module connector has 20 pins. The extra pins on the mounting rack connector prevent misalignment of the module during installation.

Part Number	Description
SNAP-AOV-27	Dual-channel analog voltage output -10 VDC to +10 VDC

Description

The SNAP-AOV-27 module provides a nominal output range of -10 to +10 volts. Each channel can supply ± 5 mA of load current.

NOTE: Both channels share a common reference terminal.

Specifications:

Input	12-bit serial data (each channel)
Outputs	-10 to +10 Volts DC
Span	20 Volts
Resolution	4.88 mV
Response Time (% of span/delta V/delta time)	99.9%/19.98 V/3 mS
DC Common Mode Rejection	>-120 dB
AC Common Mode Rejection	>-120 dB @ 60 Hz
Maximum Operating Common Mode Voltage	250 V
Common Mode Resistance	>1,000 Megohms
Load Current (nominal)	5 mA (each channel)
Short Circuit Output Current Continuous	40 mA per channel
Accuracy	0.1% of Span
Gain Temperature Coefficient	50 PPM/°C
Offset Temperature Coefficient	20 PPM/°C
Power Requirements	5 Volts DC (± 0.15) @ 150 mA
Ambient Temperature:	
Operating	0 °C to 70 °C
Storage	-25 °C to 85 °C

Dual-Channel Current Output 0–20 mA

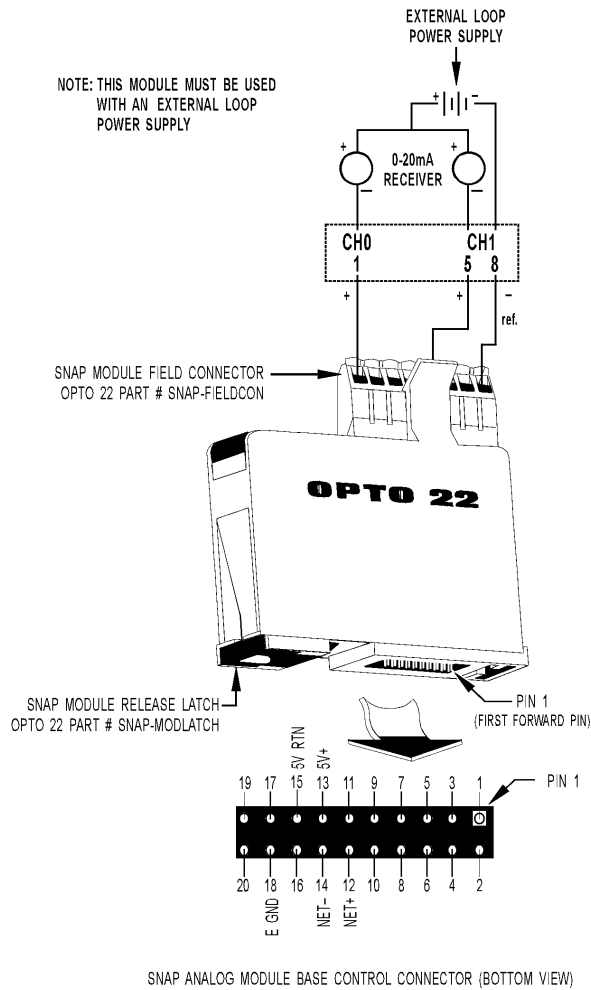

IMPORTANT: The mounting rack connector has 24 pins; the module connector has 20 pins. The extra pins on the mounting rack connector prevent misalignment of the module during installation.

SNAP Analog Output Modules

Part Number	Description
SNAP-AOA-28	Dual-channel analog output current loop 0–20 mA

Description

The SNAP-AOA-28 module provides a nominal output range of 0 mA to 20 mA. An external loop power source is required for the current loops.

NOTE: Both channels share a common reference terminal.

Specifications:

Input	12-bit serial data (each channel)										
Outputs	0 to 20 mA (each channel)										
Span	20 mA										
Resolution	4.9 microamps										
Response Time (% of span/delta I/ delta time)	99.9%/15.98 mA/3 mS										
DC Common Mode Rejection	>-120 dB										
AC Common Mode Rejection	>-120 dB @ 60 Hz										
Maximum Operating Common Mode Voltage	250 V										
Common Mode Resistance	>1000 Megohms										
Accuracy	0.1% of Span										
Gain Temperature Coefficient	50 PPM/°C										
Offset Temperature Coefficient	20 PPM/°C										
Module Power Requirements	5 Volts DC (±0.15) @ 150 mA										
Loop Power Requirements	8 Volts DC (min) to 32 Volts DC (max)										
Max. Loop Resistance (Ohms) @ Loop Supply	<table border="1"> <tr> <td>250</td> <td>450</td> <td>650</td> <td>1050</td> <td>1450</td> </tr> <tr> <td>8V</td> <td>8V</td> <td>12V</td> <td>24V</td> <td>32V</td> </tr> </table>	250	450	650	1050	1450	8V	8V	12V	24V	32V
250	450	650	1050	1450							
8V	8V	12V	24V	32V							
Max. Loop Resistance formula	$\frac{(\text{Loop Voltage} - 5)}{0.02}$										
Ambient Temperature: Operating Storage	0 °C to 70 °C -25 °C to 85 °C										

SNAP Analog Output Modules

Dual-Channel Time-Proportional Output Voltage 5–60 VDC

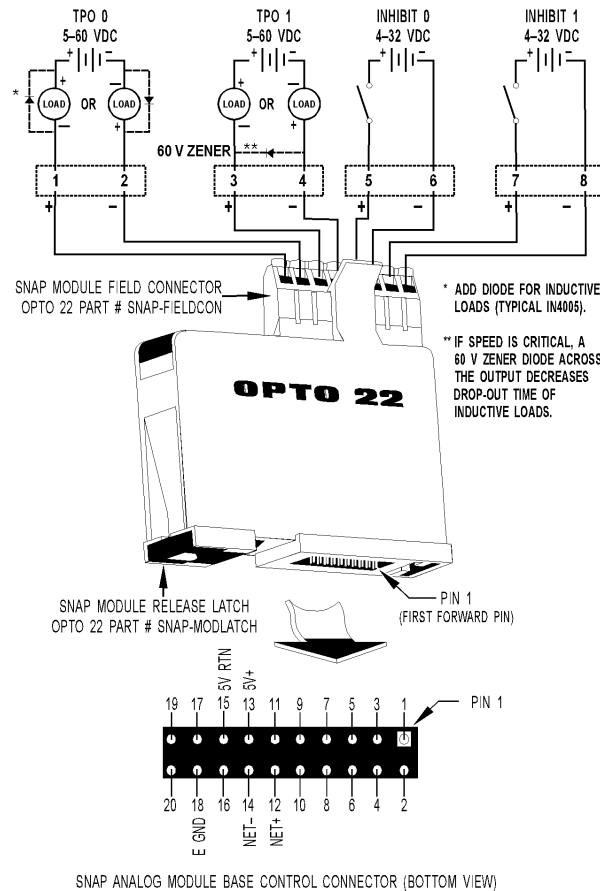

IMPORTANT: The mounting rack connector has 24 pins; the module connector has 20 pins. The extra pins on the mounting rack connector prevent misalignment of the module during installation.

Part Number	Description
SNAP-AOD-29	Dual-channel analog Time-proportional digital output 5 to 60 VDC

Description

The SNAP-AOD-29 module provides two channels of time-proportional output (TPO). The outputs are used to switch or control DC loads such as lamps or indicators, solenoids, relay coils, and PLC logic. Each TPO channel can switch 0.5 A of load current ranging from 5 VDC to 60 VDC, over a period range of .25 seconds to 64.25 seconds.

Both TPO channels also have individual “inhibit” inputs dedicated to turning off the output, a useful feature in temperature and interlock control applications. The channels are optically isolated from each other.

NOTE: The SNAP-AOD-29 module cannot be used in a SNAP PAC IO4AB system. Instead, use the built-in TPO functionality available on all SNAP-PAC brains that support IO4AB.

Specifications:

Input	12-bit serial data (each channel)
Switched Output at 45 °C Ambient at 70 °C Ambient	5 to 60 Volts DC 0.5 A 0.2 A
TPO Resolution	12-bit Each bit = Period/4095 1 millisecond/bit default
Period Range	0.251 sec. to 64.25 sec. (0.251 sec for Ethernet-based I/O units) 0.251 seconds module default
Period Accuracy	± 0.5%
Period Resolution	.251 second
Inhibit Inputs On Off	4.0 Volts DC at 1.0 mA (32 Volts DC max.) 1.0 Volt DC
Maximum Operating Common Mode Voltage	250 V
Common Mode Resistance	>1,000 Megohms
Timebase Temperature Coefficient	50 PPM/°C
Power Requirements	5 Volts DC (±0.15) @ 150 mA
Ambient Temperature: Operating Storage	0 °C to 70 °C -25 °C to 85 °C

SNAP Analog Output Modules

Dimensional Drawings

All Modules

Note: The SNAP-AOD-29 time-proportional output (TPO) module has integral LEDs for monitoring and troubleshooting the module's outputs and inhibit inputs.

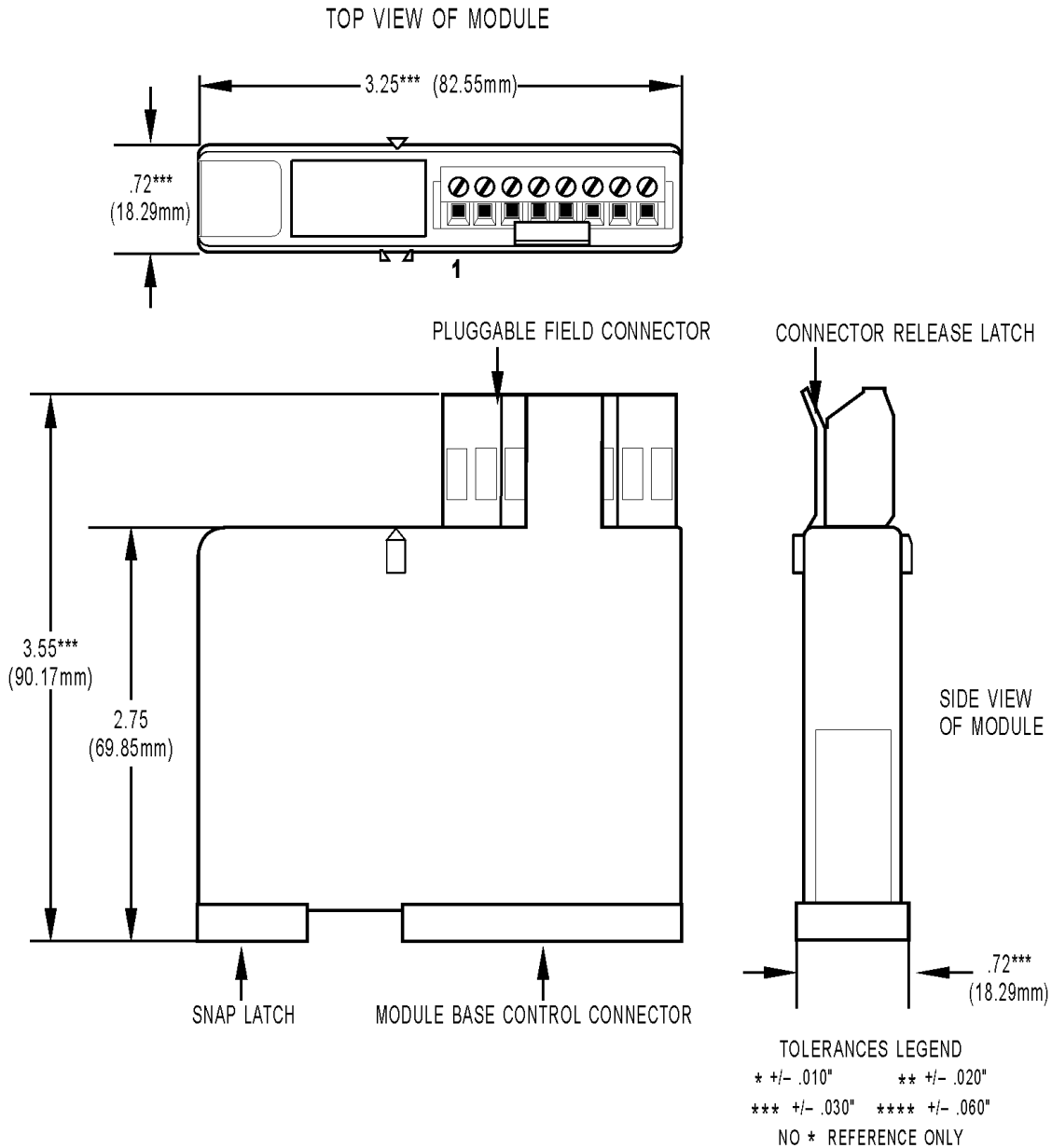

SNAP Analog Output Modules

Dimensional Drawings

All Modules

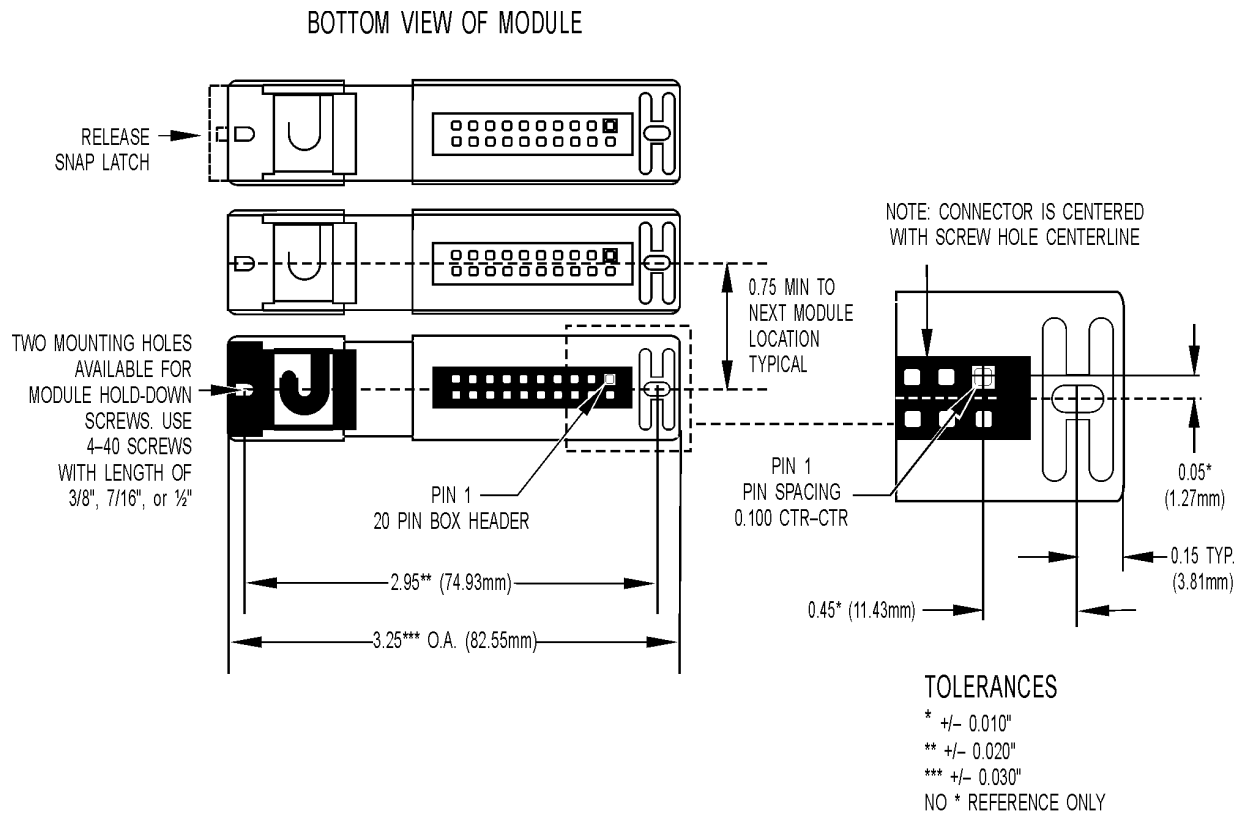

IMPORTANT: The mounting rack connector has 24 pins; the module connector has 20 pins. The extra pins on the mounting rack connector prevent misalignment of the module during installation.

SNAP Analog Output Modules

Dimensional Drawing

All Modules

SNAP Analog Module Mounted on a SNAP Rack

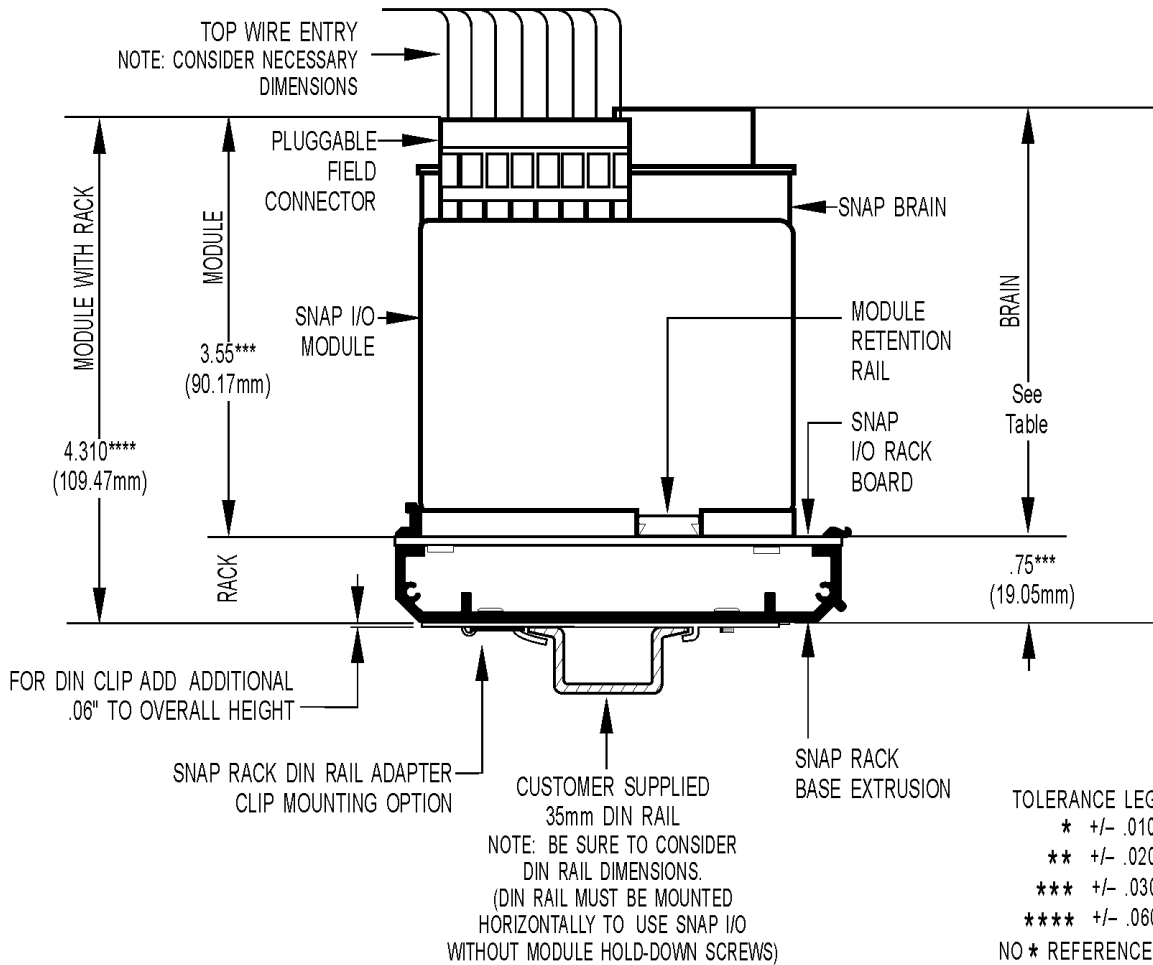

More About Opto 22

Products

Opto 22 develops and manufactures reliable, flexible, easy-to-use hardware and software products for industrial automation, remote monitoring, and data acquisition applications.

SNAP PAC System

Designed to simplify the typically complex process of understanding, selecting, buying, and applying an automation system, the SNAP PAC System consists of four integrated components:

- SNAP PAC controllers
- PAC Project™ Software Suite
- SNAP PAC brains
- SNAP I/O™

SNAP PAC Controllers

Programmable automation controllers (PACs) are multifunctional, multidomain, modular controllers based on open standards and providing an integrated development environment.

Opto 22 has been manufacturing PACs for many years. The latest models include the standalone SNAP PAC S-series and the rack-mounted SNAP PAC R-series. Both handle a wide range of digital, analog, and serial functions and are equally suited to data collection, remote monitoring, process control, and discrete and hybrid manufacturing.

SNAP PACs are based on open Ethernet and Internet Protocol (IP) standards, so you can build or extend a system without the expense and limitations of proprietary networks and protocols.

PAC Project Software Suite

Opto 22's PAC Project Software Suite provides full-featured and cost-effective control programming, HMI (human machine interface) development and runtime, OPC server, and database connectivity software to power your SNAP PAC System.

These fully integrated software applications share a single tagname database, so the data points you configure in PAC Control™ are immediately available for use in PAC Display™, OptoOPCServer™, and OptoDataLink™. Commands are in plain English; variables and I/O point names are fully descriptive.

PAC Project Basic offers control and HMI tools and is free for download on our website, www.opto22.com. PAC Project Professional, available for separate purchase, adds OptoOPCServer, OptoDataLink, options for Ethernet link redundancy or segmented networking, and support for legacy Opto 22 serial *mistic*™ I/O units.

SNAP PAC Brains

While SNAP PAC controllers provide central control and data distribution, SNAP PAC brains provide distributed intelligence for I/O processing and communications. Brains offer analog, digital, and serial functions, including thermocouple linearization; PID loop control; and optional high-speed digital counting (up to 20 kHz), quadrature counting, TPO, and pulse generation and measurement.

SNAP I/O

I/O provides the local connection to sensors and equipment. Opto 22 SNAP I/O offers 1 to 32 points of reliable I/O per module, depending on the type of module and your needs. Analog, digital, serial, and special-purpose modules are all mixed on the same mounting rack and controlled by the same processor (SNAP PAC brain or rack-mounted controller).

Quality

Founded in 1974 and with over 85 million devices sold, Opto 22 has established a worldwide reputation for high-quality products. All are made in the U.S.A. at our manufacturing facility in Temecula, California. Because we do no statistical testing and each part is tested twice before leaving our factory, we can guarantee most solid-state relays and optically isolated I/O modules for life.

Free Product Support

Opto 22's Product Support Group offers free, comprehensive technical support for Opto 22 products. Our staff of support engineers represents decades of training and experience. Product support is available in English and Spanish, by phone or email, Monday through Friday, 7 a.m. to 5 p.m. PST.

Free Customer Training

Hands-on training classes for the SNAP PAC System are offered at our headquarters in Temecula, California. Each student has his or her own learning station; classes are limited to nine students. Registration for the free training class is on a first-come, first-served basis. See our website, www.opto22.com, for more information or email training@opto22.com.

Purchasing Opto 22 Products

Opto 22 products are sold directly and through a worldwide network of distributors, partners, and system integrators. For more information, contact Opto 22 headquarters at 800-321-6786 or 951-695-3000, or visit our website at www.opto22.com.

www.opto22.com